

Remote Camera Link over Fiber-Optic System (RCLF)

Key Features

- Transmit distance with no repeaters: 2Km. For other distances of up to 40 km, contact the Gidel Support (support@gidel.com)
- Support for all Camera Link modes including 80-bit (DECA).
- Option for connecting two Camera Link cameras in Base mode.
- Direct connection to Gidel's Frame grabber thus reducing server infrastructure cost and components.
- SFP+ cage for up to 6.25 Gb/s full duplex data transfer over fiber optics cable.
- Remote I/O capabilities including:
 - RS232 Rx/Tx
 - 2x 3-30V opto-couplers output driver
 - 2x 3-30V opto-coupler input receivers
 - 4 Camera Control lines and serial communication in accordance to the Camera Link specification.
 - Triggering capabilities from frame grabber.
 - Frame Grabber I/O lines enabling driving and receiving up to 30V.
- I/O controls from host PC:
 - Camera Link Serial communication (CLSER)
 - Virtual COM for RS232 and Camera Link
- Status LEDs indicating power, link connection, transmission activity, and user defined functionality.



The Remote Camera Link Fiber-Optic (RCLF) extension system enables frame acquisition from a remote camera at a distance of up to 40 km without repeaters. A remote camera connects directly to the RCLF module that transmits the camera image over fiber optic cables to either a Gidel PCIe HawkEye-CL frame grabber board mounted in a host computer or to another Gidel RCLGR module that can interface with any user frame grabber.

The RCLF supports all Camera Link modes including 80 bit (DECA) and an option to connect two Base mode cameras.

The RCLF unit is supported by remote I/O capabilities via the fiber optics cable, including:

1. Camera control lines for remote controlling of the camera as defined by the Camera Link protocol.
2. Camera Link serial communication.
3. Dedicated I/O interface for RS232 and GPIO.
4. 3-30V opto-coupler drivers and receivers.

Interfacing with the Gidel HawkEye-CL frame grabber offers both high performance acquisition from the remote camera as well as on-board real-time image processing capability.



North America:

1600 Wyatt Drive, Suite 1
Santa Clara, CA 95054
+1-408-969-0389
sales_usa@gidel.com

International:

2 Ha'ilan St., Northern Ind. Zone
POB 281, Or Akiva, Israel 3060000
+972-4-610-2500
sales_eu@gidel.com

www.gidel.com

Remote Camera Link over Fiber Optics (RCLF)

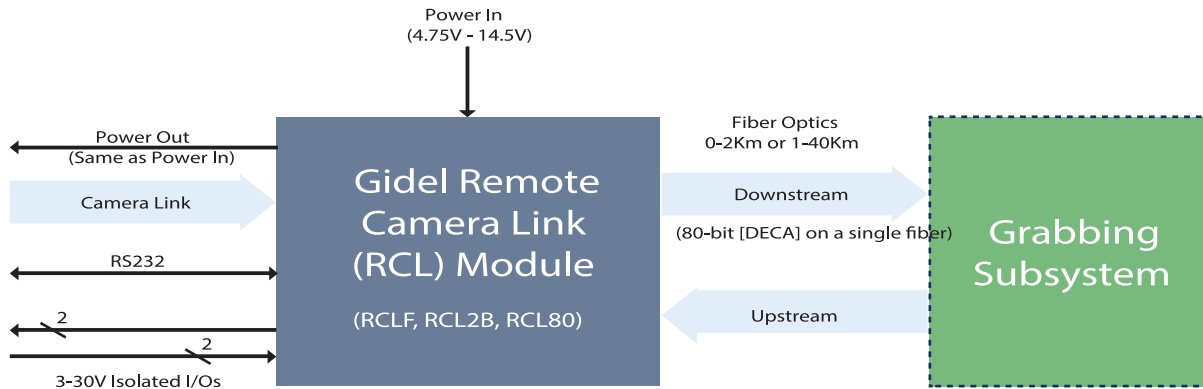

Remote Camera over Fiber Optic System

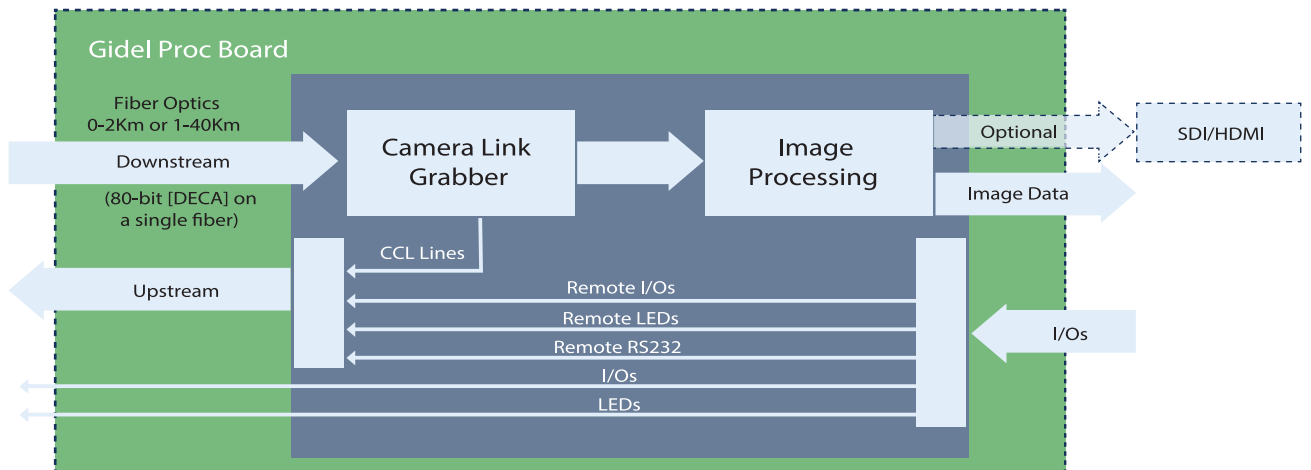

Grabbing subsystem based on Gidel Frame Grabber & Processing

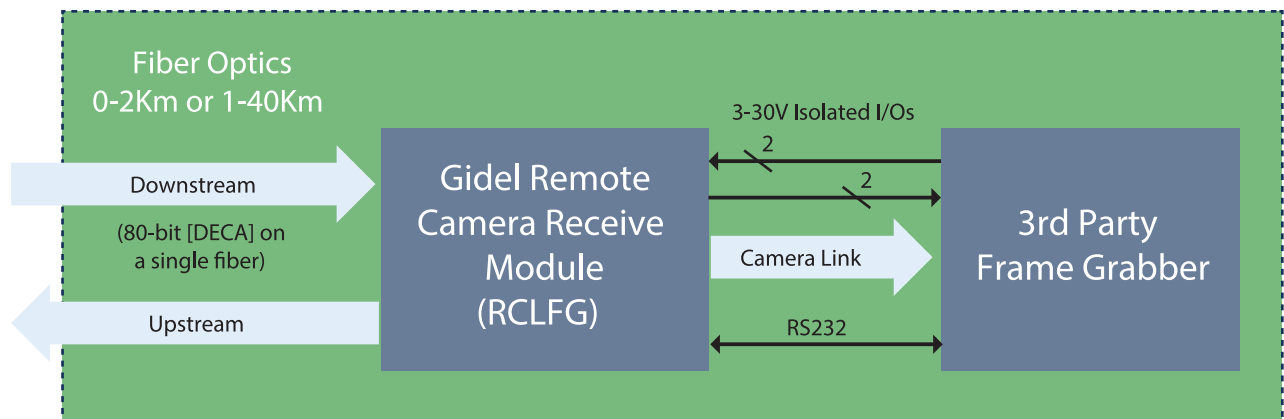

Grabbing subsystem based on 3rd party Frame Grabber